



Modelo

VENTI706X

EAN 8435666508010

Características

Campana de pared

Ancho 70 cm

Inox

Control con botonera

3 niveles de potencia

Capacidad de extracción: 640 m³/h

(Mín: 280 m³/h - Máx: 640 m³/h)

Iluminación LED: 2x1,5W

2 Filtros de aluminio lavable

Clase energética C

Potencia motor: 215W/Potencia total: 218W

Potencia sonora: 67 dB

Instalación en recirculación opcional

(accesorios filtros de carbón TL1200 por separado)

Dimensiones (AlxAnxFon cm):

55/102 (mín/máx)x69,8x50

Diagrama de instalación

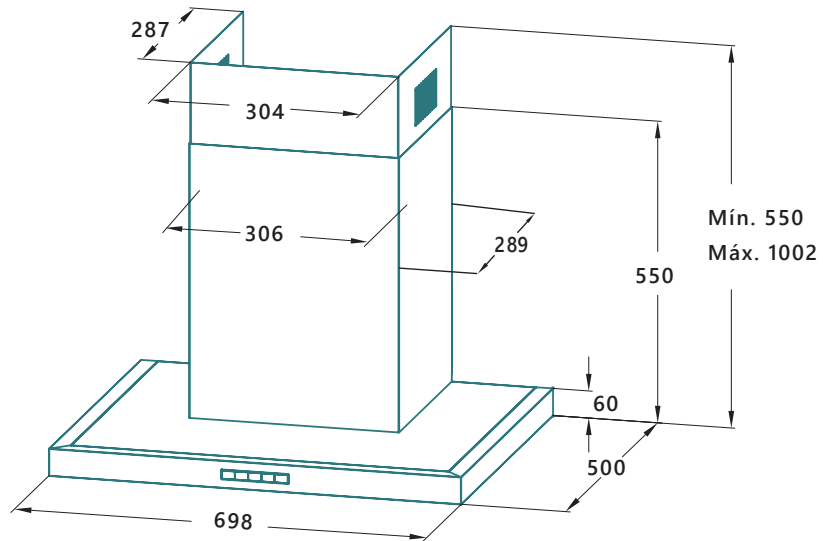

Medidas en mm